

PRESSURE RELIEF VALVES & DEVICES

With/Without Contacts

Size : 50mm to 150mm for oil filled Distribution & Power Transformers



VIAT

INSTRUMENTS

VI-03(R1)



MONITOR PRESSURE IN YOUR TRANSFORMERS

Pressure Relief Valves



● For single phase & small 3 phase distribution transformers

- Sizes 1/4" BSP/NPT.
- Every PRV tested for operating and resealing pressure.
- Complete kit with accessories, washers and nuts included.
- Operating pressure from 5psi (0.35 bar) to 15psi (1.05 bar).

● For distribution transformers

- Sizes 3/4" and 1" BSP (ISO thread).
- Operating pressure from 0.20 bar (20 Kpa) to 0.70 bar (70 Kpa) factory preset.
- Each PRV is individually calibrated for operation and resealing.
- Available in forged brass / aluminium body.



● For small power transformers

- Size 50 & 80 mm with/without single/double switches.
- Optional direction cover.
- Online computerised certificate for each serialized unit.
- Leakage test at 80% of operating pressure on each unit.
- All stainless steel, brass and aluminium construction.

● For power transformers

- Size 150 with single or double switches.
- Optional direction shroud.
- Top cover/side switch mounting options.
- Fully computerised online recorded certificate with each unit.

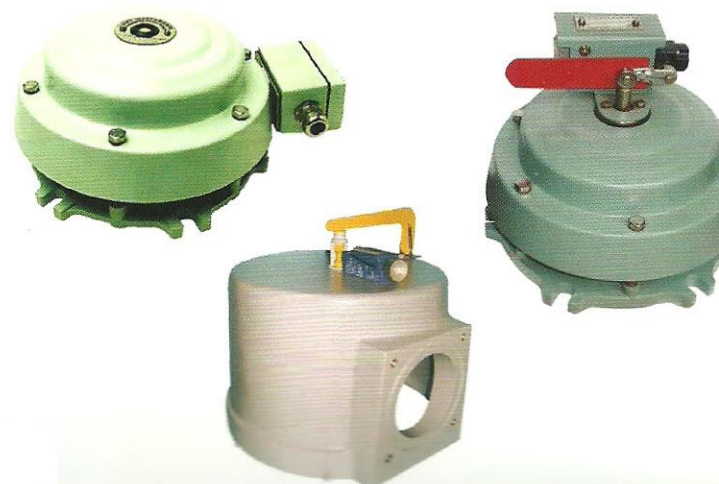

PRESSURE RELIEF VALVE

Model T-50 (50mm) T-80 (80mm) Without Switch



Type	Size	Model No	Switch	Cover
T50	50	306XX01	NO	NO
T80	80	307XX01	NO	NO

XX-Replace by operating pressure in KPA
 Example Type T50 PRD without switch & SS cover and operating pressure 50 KPA will be model no. 3065001

FEATURES

- Available in standard factory preset pressure setting between 20 to 70kpa (3 to 10psi).
- Electric signal switch optional.
- Stainless steel directional cover.
- Gas bleed screw in all models.
- Each unit has individual serial number and test certificate with exact value of operation pressure.
- All stainless steel/brass hardware for extreme outdoor conditions.
- Electrostatic powder coated body.
- Operating pressure tolerance of ± 3 kpa for PRV upto 40kpa, ± 5 kpa for PRV between 40 and 70.
- Computerised on-line test certificate for operating and resealing pressure for individual units.

T-50 Without Switch

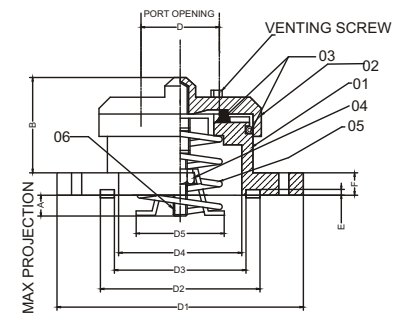
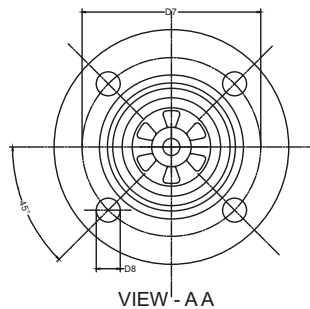

T-50 Without Switch With Indicator

Type	Size	Model No	Switch	Cover
T50	50	306XX03	NO	NO
T80	80	307XX03	NO	NO

XX-Replace by operating pressure in KPA
 Example Type T50 PRD with SS cover and operating pressure 50 KPA will be model no. 3065003

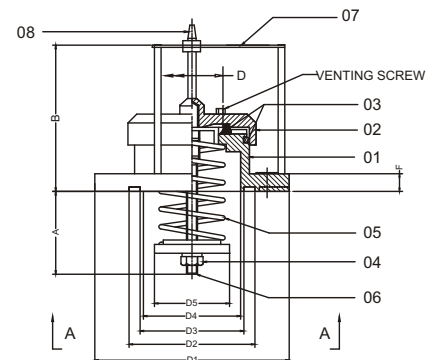
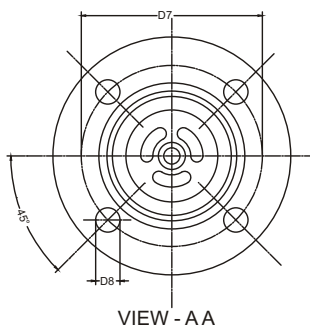

Parts List :

PART NO.	DESCRIPTION	MATERIAL
01.	BODY	ALUMINIUM
02.	SHUTTER	ALUMINIUM
03.	GASKET RUBBER	NBR
04.	NUT	BRASS
05.	SPRING	STAINLESS STEEL
06.	TIE ROD	BRASS
07.	PROTECTIVE PLATE	MS (POWDER COATED)
08.	YELLOW INDICATOR	ALUMINIUM/ BRASS

MODEL	TYPE	DIMENSIONS													
		D	D1	D2	D3	D4 MAX	D5 MAX	D6	D7	D8	A * MAX	B	C MAX	E	F
306XX01	T50	50	165	99	85	81	61	NA	125	18	25	78	NA	4	14
307XX01	T80	80	200	131	117	112	102	NA	160	18	25	103	NA	4	16
306XX03	T50	50	165	99	85	81	61	NA	125	18	54	127	NA	NA	14
307XX03	T80	80	200	131	117	112	99	NA	160	18	70	145	NA	NA	16

* The dimension varies with set pressure

General Information : FINISH : RAL 7001 POWDER COATED

PRESSURE RELIEF VALVE

Model T-50 (50mm) T-80 (80mm) With Switch



T-50 With Switch

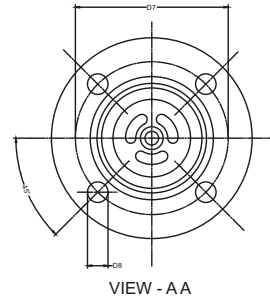

VIEW - A A

Type	Size	Model No	Switch	Cover
T50	50	306XX02	YES	NO
T80	80	307XX02	YES	NO

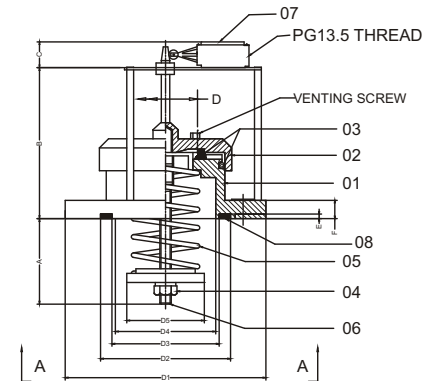

XX-Replace by operating pressure in KPA
Example Type T50 PRD with switch and operating pressure 50 KPA will be model no. 3065002



T-50 With Switch & Direction Cover

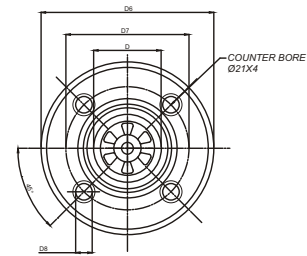

VIEW - A A

Type	Size	Model No	Switch	Cover
T50	50	306XX06	1N0+1NC	YES
T80	80	307XX06	1N0+1NC	YES
T50	50	306XX06-2	2N0+2NC	YES
T80	80	307XX06-2	2N0+2NC	YES

XX-Replace by operating pressure in KPA
Example Type T50 PRD with switch, direction cover and operating pressure 50 KPA will be model no. 3065006

Parts List :

PART NO.	DESCRIPTION	MATERIAL
01.	BODY	ALUMINIUM
02.	SHUTTER	ALUMINIUM
03.	GASKET RUBBER	NBR
04.	NUT	BRASS
05.	SPRING	STAINLESS STEEL
06.	TIE ROD	BRASS
07.	SWITCH	CONNECTOR THREAD PG13.5/M20
08.	MOUNTING RUBBER & ALL RUBBER COMP.	NBR
09.	PLUNGER HOLDER	ALUMINIUM
10.	PROTECTIVE COVER	STAINLESS STEEL

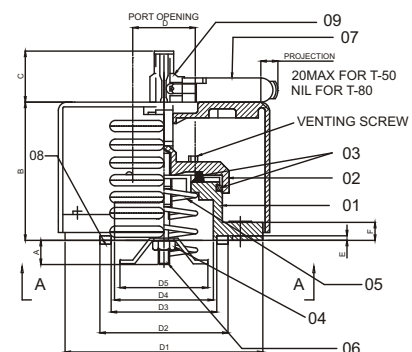

MODEL	TYPE	DIMENSIONS													
		D	D1	D2	D3	D4 MAX	D5 MAX	D6	D7	D8	A * MAX	B	C MAX	E	F
306XX02	T50	50	165	99	85	81	61	NA	125	18	25	127	30	4	14
307XX02	T80	80	200	131	117	112	99	NA	160	18	25	145	30	4	16
306XX06	T50	50	165	99	85	81	61	172	125	18	25	127	47	4	14
307XX06	T80	80	200	131	117	112	102	205	160	18	25	160	47	4	16

* The dimension varies with set pressure

PRESSURE RELIEF VALVE TYPE T-50

With Cover & Switch Integrated (Switch Trigger Below The Cover)

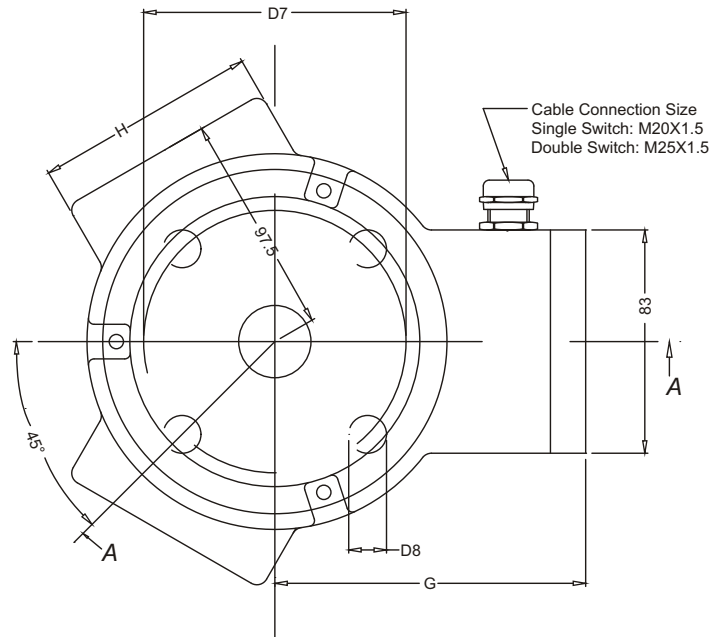

Type	Size	Model No	Switch	Cover
T50	50	306XX09	1NO+1NC	YES
T50	50	306XX09-2	2NO+2NC	YES

XX-Replace by operating pressure in KPA
 Example Type T50 PRD with switch and cover and operating pressure 50 KPA will be model no. 3065009

Contact Type :

Single Switch

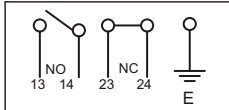

Double Switch

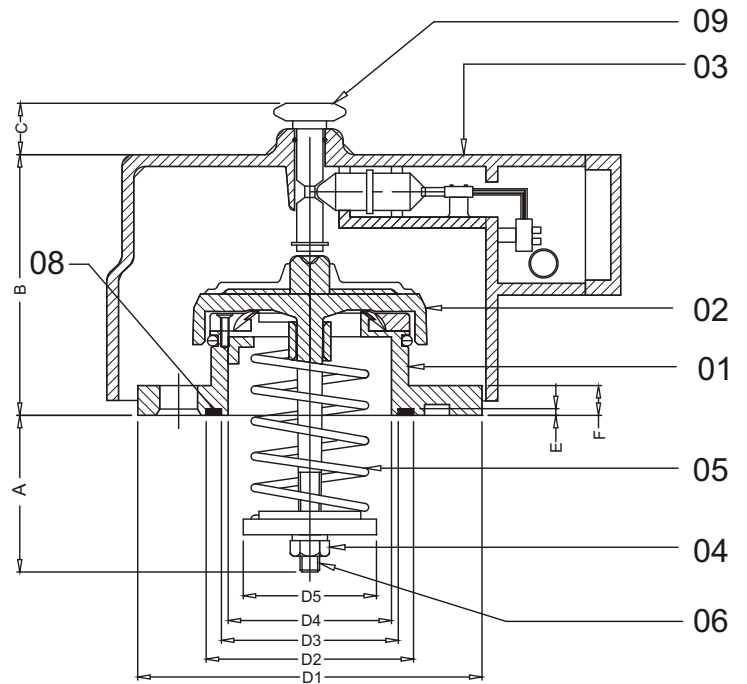
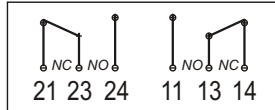

Parts List :

PART NO.	DESCRIPTION	MATERIAL
01.	BODY	ALUMINIUM ALLOY
02.	SHUTTER	ALUMINIUM ALLOY
03.	PROTECTIVE SHROUD	STAINLESS STEEL
04.	NUT	STAINLESS STEEL
05.	SPRING	SPRING STEEL
06.	TIE ROD	STAINLESS STEEL
07.	SWITCH	CONNECTOR THREAD PG13.5/M20
08.	MOUNTING RUBBER & ALL RUBBER COMP.	NBR
09.	VISUAL INDICATOR	BRASS

TYPE	DIMENSIONS															
	D	D1	D2	D3	D4 MAX	D5 MAX	D6	D7	D8	A* MAX	B	C	E	F	H	J
T50	50	165	99	85	81	61	175	125	18	60	130.5	13	4	14	100	97.5
T80	80	200	131	117	112	102	212	160	18	60	160	13	4	16	117	130

General Information : FINISH : RAL 7001 POWDER COATED

PRESSURE RELIEF VALVE TYPE T-50 (50mm) & T-80 (80mm)

With Switch & Threaded/Flange Type Direction Shroud

T50 With Flanged Direction Shroud & 2NO+2NC Contacts

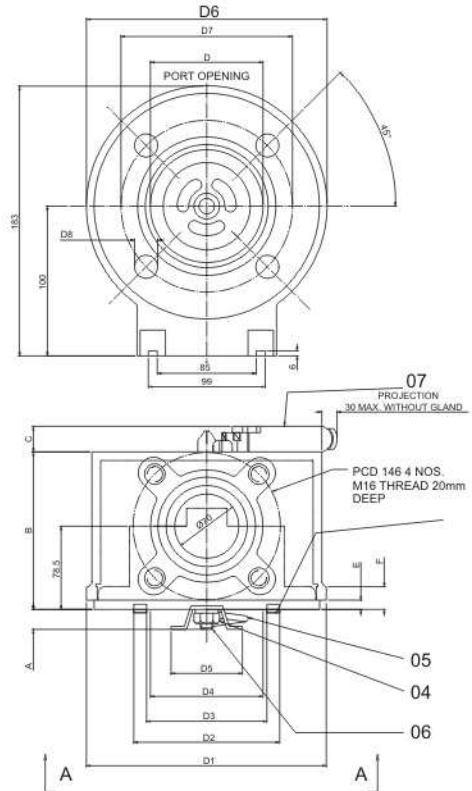

SWITCH RATING

NZ1RS-3131-M
IEC 60947-5-1 IP67
AC- 15, 6A, 230V
DC- 13, 6A, 24V

TYPE	DIMENSIONS													
	D	D1	D2	D3	D4 MAX	D5 MAX	D6	D7	D8	A* MAX	B	C	E	F
T50	50	165	99	85	81	50	NA	125	18	75	130.5	28	4	14

General Infomation : FINISH : RAL 7001 POWDER COATED

T80 With Threaded Direction Shroud & 2NO Contacts

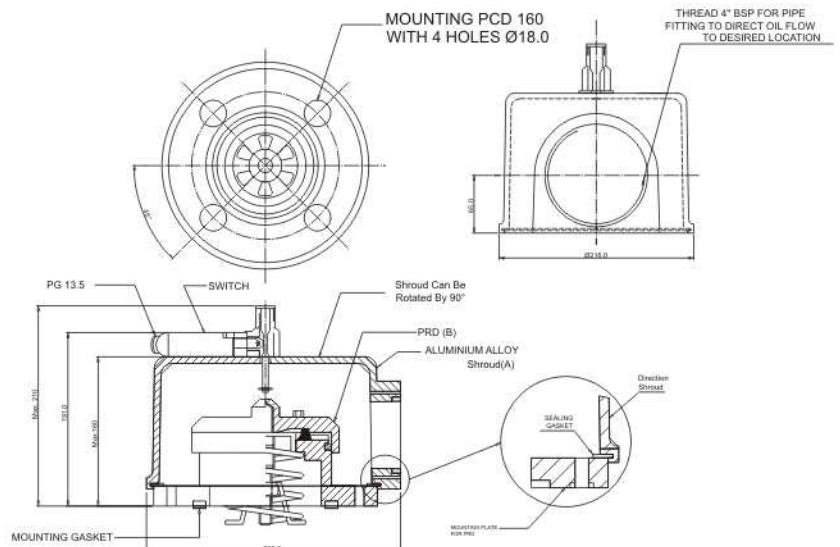

Switch Operation	Specification
<p>BEFORE OPERATION</p>	IEC/60947-5-1 Ui: 400V Uimp : 4kv AC15 240V 1.5A Ith 6A IP 66 - IP 67
<p>AFTER OPERATION</p>	

PRESSURE RELIEF VALVE TYPE T-2 (50mm) To T-6 (150mm)

With Switch (Economy Model)

T2 With Switch

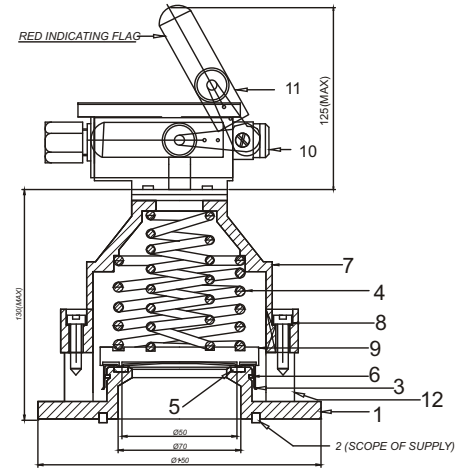
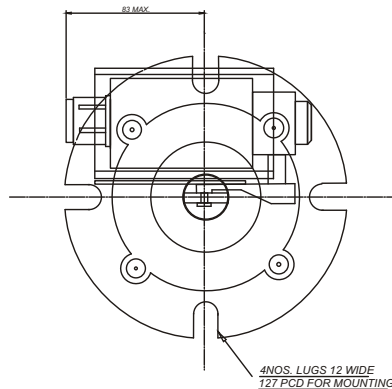

Parts List

SL	DESCRIPTION	MATERIAL/MFG.	QTY
1.	BASE	AL. ALLOY	1
2.	MOUNTING RING	NBR	1
3.	DIAPHRAGM	S.S	1
4.	SPRING	SPRING STEEL	1 / 2
5&6	GASKET	NBR	2
7.	COVER	AL. ALLOY	1
8.	SCREWS	S.S	4
9.	SPRING RETAINER	AL.	1
10.	SWITCH ASSY. (1 NO + 1 NC)	HONEYWELL	1
11.	FLAG	AL. ALLOY	1
12.	SPACER	S.S	4

T6 With Switch

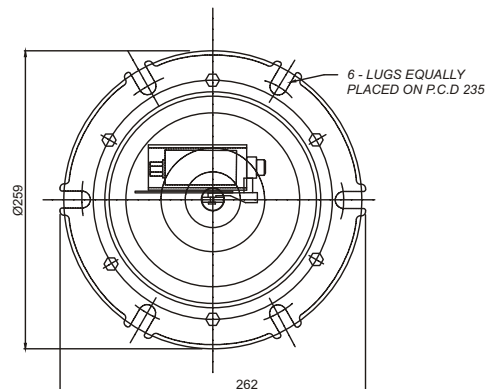
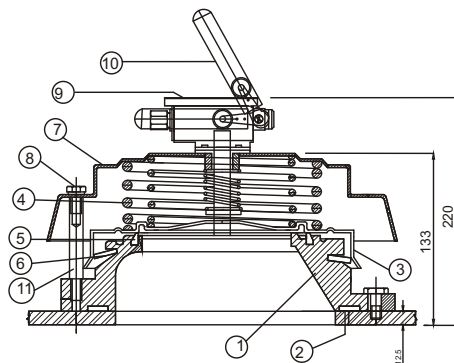

Parts List

SL	DESCRIPTION	MATERIAL/MFG.	QTY
1.	BASE	AL. ALLOY	1
2.	MOUNTING RING	NBR	1
3.	DIAPHRAGM	S.S	1
4.	SPRING	SPRING STEEL	2
5&6	GASKET	NBR	2
7.	COVER	AL. ALLOY	1
8.	SCREWS	S.S	6
9.	SWITCH ASSY. (1 NO + 1 NC)	HONEYWELL	1
10.	INDICATOR	AL.	1
11.	SPACER	S.S	6

Technical Specification

Operating pressure : 0.42kg/cm² to 0.70kg/cm² (6 to 10psi)
 Operating tolerance : ±0.07kg/cm² (±1psi)
 Switch : Limit switch SPDT (1NO+1NC) or DPDT (2NO+2NC)
 Switch rating : 10Amps 300V AC, 6Amps 24V DC
 Cable entry : T3 - 3/4" BSC, T6- 1" BSC
 Port opening : T2 - 50mm., T6 - 150mm.

PRESSURE RELIEF VALVE FOR OIL FILLED POWER TRANSFORMERS

Size: 150mm Model - 305



MODEL NUMBER	OPERATING PRESSURE		GASKET	INDICATOR
	PSI	BAR		
3050401	4±1	0.28±0.07	NBR	YELLOW
3050501	5±1	0.35±0.07		
3050801	8±1	0.56±0.07		
3051001	10±1	0.70±0.07		
3051201	12±1	0.84±0.07		
3052001	20±2	1.40±0.14		
3052501	25±3	1.75±0.21	VITON	RED
3050405	4±1	0.28±0.07		
3050505	5±1	0.35±0.07		
3050805	8±1	0.56±0.07		
3051005	10±1	0.70±0.07		
3051205	12±1	0.84±0.07		
3052005	20±2	1.40±0.14		
3052505	25±3	1.75±0.21		

GENERAL INFORMATION :

- BLEED SCREW**
Is A Standard Feature In All Models.
- FINISH**
Light grey ASA 70/RAL 7035 powder coated.
- SEMAPHORE**
Part No. 501 is optional, to be ordered separately.
- GASKET**
NBR (Nitrile) for transformer oil
Viton for silicon oil

FEATURES

- Gas bleed system standard in all models.
- An additional test arm provided to check operation of switch.
- Teflon coated stainless steel operating disc with deep drawn spring locator.
- Pressure die cast, vacuum impregnated and pure polyester powder coated mounting flange.
- All stainless steel hardware.
- Springs made out of oil hardened and tempered spring steel wire to provide uniform loading and to prevent fatigue failure.
- Springs specially treated and coated to prevent rust and corrosion due to harsh environment.
- Inner and outer springs reverse wound and paired for consistent operating pressure.
- Paint to shade Light Grey ASA 70.
- Computerised on line test certificate for each individual unit.

WORKING

When pressure in the tank rises, the total force on the area defined by the top gasket on the operating disc also increases. As soon as this force exceeds the load applied by the springs, the operating disc moves slightly upwards. This exposes the transformer pressure to a greater area corresponding to the diameter of side gasket, resulting in sudden increase of force. The disc lifts instantaneously and vents out the excess pressure in the transformer. When the pressure falls to allowable values, the spring forces the disc back to its original position.

APPLICATION

These Pressure Relief Devices are recommended to be used on all sizes of transformers ranging from distribution transformers to large power transformers. For very large power transformers, it is usual to use multiple devices. Normally one device is used for every 10,000 gallons (35000 litres approx.) of cooling liquid.

MOUNTING & MAINTENANCE

These Pressure Relief Devices should be preferably mounted in the horizontal position, top side up.

The device has rugged construction and does not require maintenance. The operating pressure is factory preset and cannot be changed at site. It is strongly recommended that the compression screws on the cover be never removed without use of extreme caution.

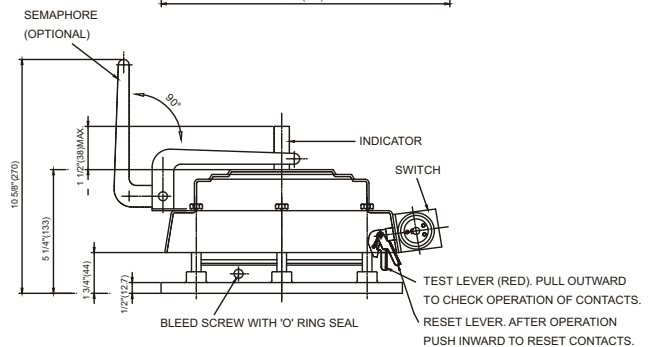
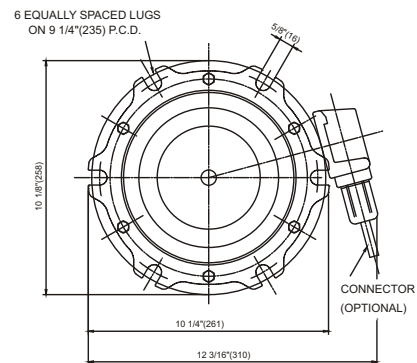

Switch With Terminal Box



Wiring Diagram Swt. 706/7

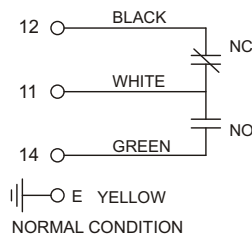

Wiring Diagram Swt. 708

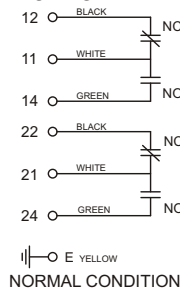

Switch With Detachable Connector



Wiring Diagram Swt. 701

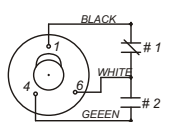

Wiring Diagram Swt. 702

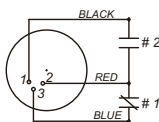

Wiring Diagram Swt. 703

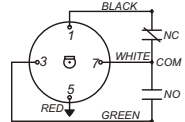

Wiring Diagram Swt. 704

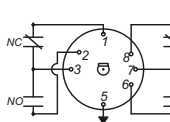

Wiring Diagram Swt. 705

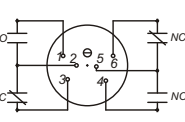

DIRECTION SHROUD FOR PRESSURE RELIEF DEVICE (150mm)

Model - 502-9

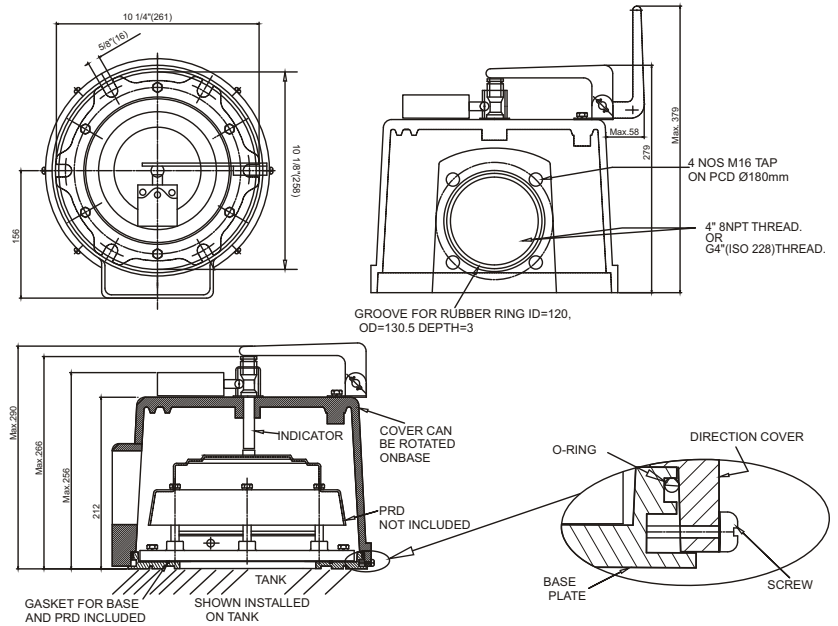

MODEL NO.	SPECIFICATION
502	DIRECTION COVER G4"(ISO228) M16X4HOLE WITHOUT SWITCH
505	DIRECTION COVER 4"NPT WITHOUT SWITCH
506	DIRECTION COVER 4"NPT WITH ONE SWITCH
507	DIRECTION COVER 4"NPT WITH TWO SWITCHES
508	DIRECTION COVER G4"(ISO228) M16X4HOLE WITH ONE SWITCH
509	DIRECTION COVER G4"(ISO228) M16X4HOLE WITH TWO SWITCHES

Description:-

The VIAT series 502-9 direction cover for pressure relief devices is designed to direct the spray of oil and gas should the pressure relief devices operate. It provides a full 360° rotation for complete flexibility in directing the spray. The compact geometry facilitates retrofit in even the tightest quarters and the included base plate provides a consistent sealing surface regardless of tank mounting flange size.

To install the cover refer installation sheet included in every box of direction cover.

The base is vented to allow for drainage of moisture. The cover opening includes a 4" tapered/straight pipe thread to accept standard pipe for duct work. The pipe should be supported separately.

The use of cast aluminium assures durability and resistance to the temperature and pressure of the oil.

A bright yellow semaphore is included as standard and provides highly visual indication of PRD operation.

This direction cover is not designed to be used with the standard VIAT side mounted alarm switch.

Single/ Double externally mounted switch on direction cover is available as an option, and provides easy test and reset capability from outside the cover. The standard external switch is IP67 with gland entry for flexibility of connection at site.

Due to our policy of continuous product improvement, dimensions and designs are subject to change.



VIAT INSTRUMENTS PVT. LTD.

2701 to 2704, Shilpangan Phase-II, Block LB-1
Sector-III, Salt Lake, Kolkata - 700 098, INDIA
Phones : (91-33) 9903805104, 23352925 ● Fax : (91-33) 23352926
E-mail : viatin@viatin.com ● Website : www.viatin.com

VIAT AMERICA, INC.

30 Shepard, Irvine, CA 92620
Tel: 949-679-0950 Fax: 949-417-1358
E-mail : sales@viatamerica.com
Website : www.viatamerica.com